

Shows the case where the device is separated from the membrane by a tile bed or similar. Also drawn to show a bolt drilled later.

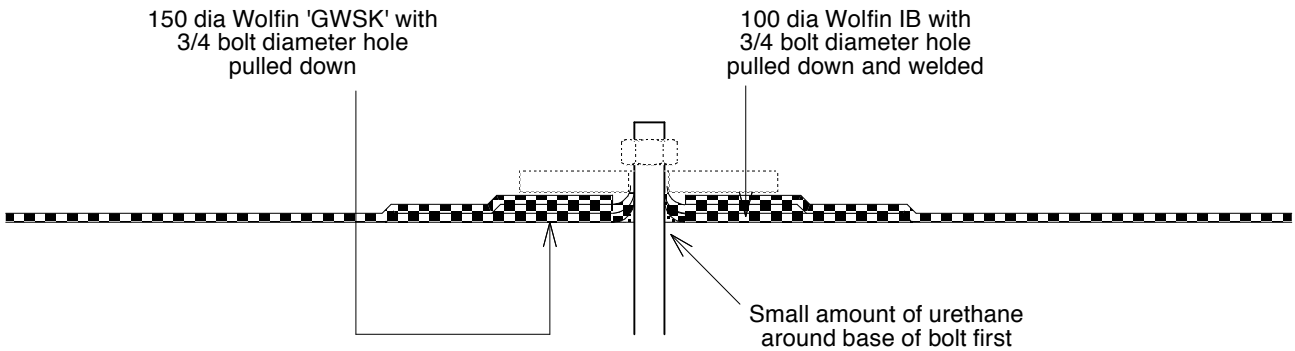

TYPICAL DETAIL AT BOLTS PENETRATING MEMBRANE

DETAIL SD 9.02

<p>This drawing is intended to show basic principles and set minimum standards. Any variation in site conditions is to be referred to WMA for approval of the required detail. The thickness scale on this drawing is exaggerated for clarity.</p>		<p>COMMENTS / ASSOCIATED DRAWINGS</p>	
<p>© WOLFIN MEMBRANES AUSTRALIA PTY LTD</p>		<p>Scale: 1 : 5</p>	
<p>Standard Guide Details</p>		<p>Bolt Details</p>	
		<p>Date: Jan 2010</p>	
		<p>Dwg No: SD - 9.02</p>	